

series 272

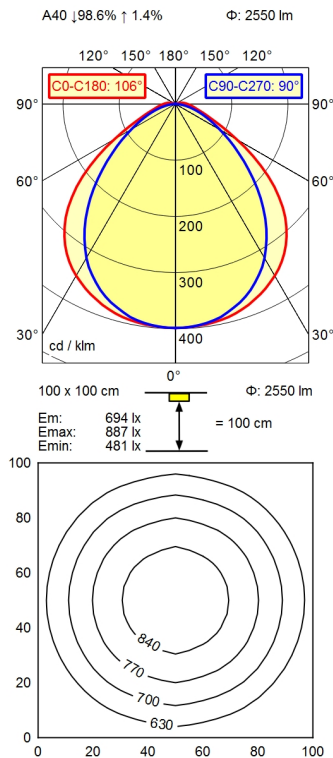

light source
work equipment
connected load
power consumption
luminous flux
luminous efficiency
light type/-color
colour temperatur
color rendering index
light distribution
direct ratio
beam angle
chromaticity tolerance LED
glare control
luminance (L65)
unified glare rating (4H 8H)
system of protection
class of protection
technology
operation
housing
cover
weight (net)
mains lead
fastening
dimension
side part
light output
special features

LED
 without
 230V, 50/60Hz
 env. 32 W
 approx. 2.550 lm
 approx. 80 lm/W
 cold white
 approx. 5.000 K
 CRI > 80
 direct
 approx. 99 %
 100°
 < 4 SDCM
 diffuser foil
 <= 17000 cd/m²
 <= 25
 IP 67
 I
 switchable; no notice
 external
 borosilicate glass
 borosilicate
 env. 2,4 kg
 connector; series 272
 pipe clamp (accessory)
 A=650 mm
 A with screwed cable gland
 D=596 mm
 light forming